



FU Series

Hydraulic oil transfer and filtration portable unit



Technical information

Frame

- Single phase electric motor 0,18 Kw, 4 poles, 230 V 50 Hz.
- Y type filter, 500 μm , for pump protection.
- Gear pump 15 l/min.
- Safety relief valve set at 6 bar.

Overall dimensions (LxPxH): 480 x 520 x 620 mm.

Weight: 23,5 kg for FU0020
25 kg for FU0030

Filter Elements

Before start a filter element must be fitted in the filter housing:
for FU0020 refer to FA series catalogue, size A12x
for FU0030 refer to F040 series catalogue, size DMD0030
N.B. we recommend filtration with fiber media 03

Working temperature: 0°C +80°C

Common

Fluid compatibility (acc.to ISO 2943):

Full with fluids HH-HG-HL-HM-HR-HV (acc.to ISO 6743/4)

Viscosity: from 30 cSt to 150 cSt

For use with other fluids please contact the FILTREC Customer Service (info@filtrec.it)

The unit is supplied complete with a Use and Maintenance Manual and it can be used only by authorized operators, that have read and understood completely the Manual.

The FU units are CE certified

ELECTRIC DIAGRAM

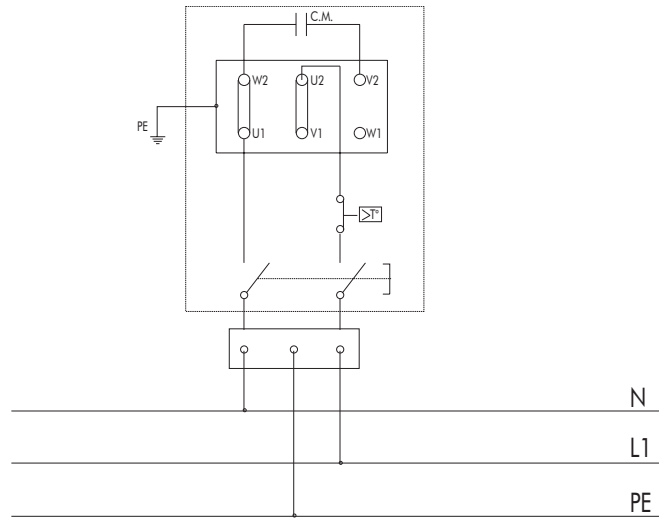

HYDRAULIC DIAGRAM

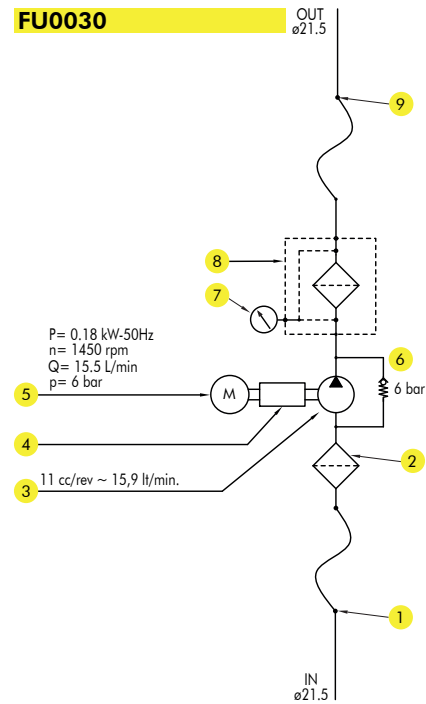
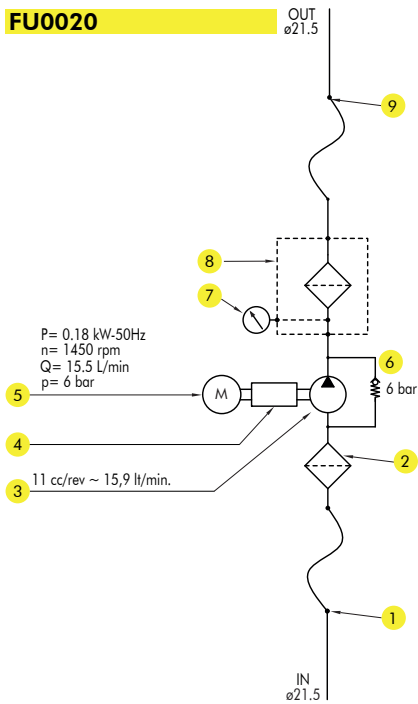

POS	DESCRIPTION
1	Flexible hose l = 3 m with rigid end
2	Suction filter "Y" type
3	Gear pump 15 l/min.
4	Motor-pump coupling arrangement
5	Single phase leelectric motor 0,18 kw with start/stop button
6	Safety relief valve
7	Clogging indicator
8	Filter housing
9	Flexible hose l = 3 m with rigid end

Overall dimensions

FU0020

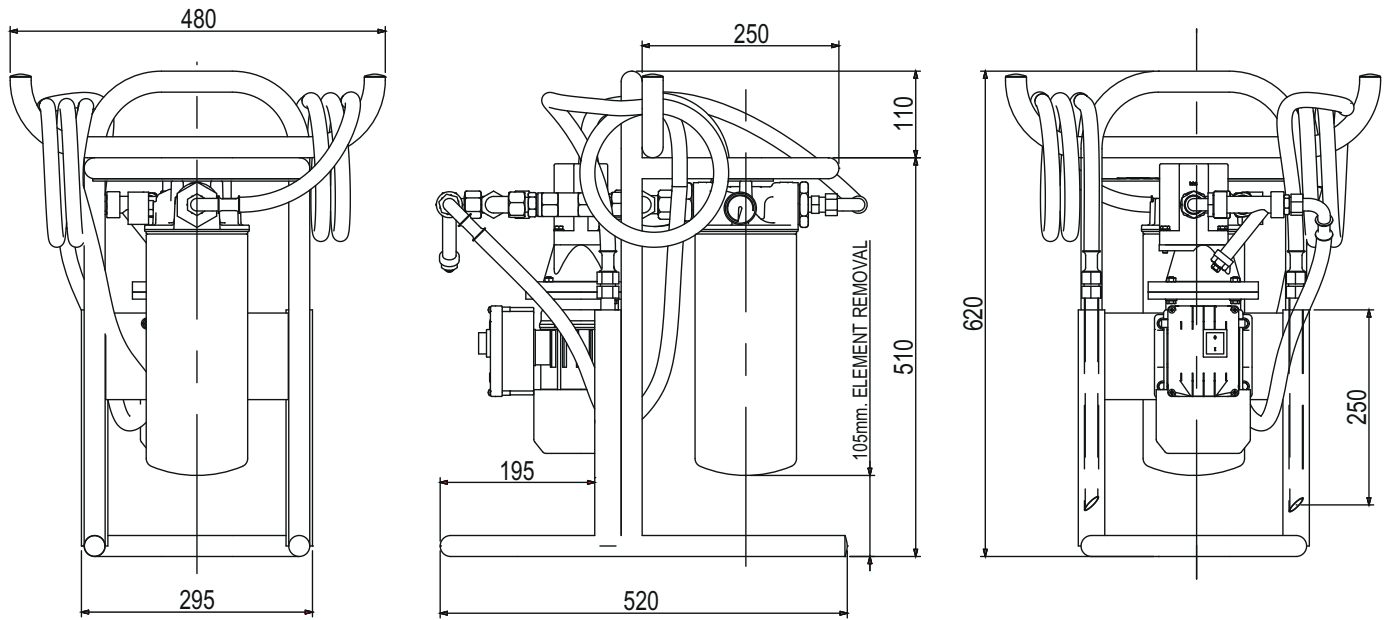

FU0030

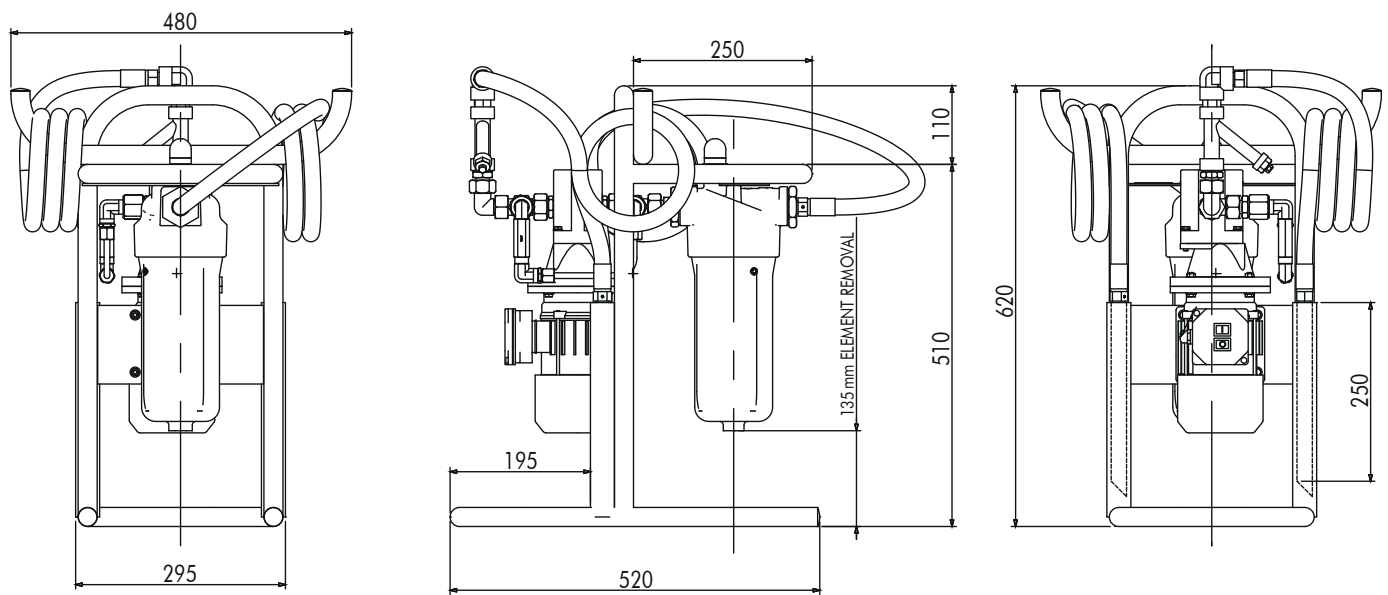

Ordering information

MODEL	
0020	fits filter cartridge A120xxx o A121xxx
0030	fits filter element DMD0030xxx

MODEL	ELECTRIC MOTOR	FLOW RATE	SEALS	VERSION
0020	4 M	015	B	01

ELECTRIC MOTOR	
4	4 poles electric motor

ELECTRIC MOTOR	
M	single phase electric motor

FLOW RATE	
015	flow rate 15 l/min

SEALS	
B	NBR

VERSION	
01	standard version

Filters maintenance

For FU0020: the inline filter is complete with a clogging indicator (pressure gauge), the filter cartridge must be replaced when the pointer reaches the red sector.
For further information please refer to the Use and Maintenance Handbook and to the technical datasheet of the FA1 series.

For FU0030: the inline filter is complete with a differential clogging indicator, the filter element must be replaced when the green sector switches to red.
For further information please refer to the Use and Maintenance Handbook and to the technical datasheet of the F040 series.

